

郑州永特机械有限公司

Zhengzhou Uniaote Machinery Co., Ltd.



报价单

QUOTATION



联系人:
Contacts: (Mr)Taka Chang



手机:
Mobile-PH: +86 17737712080



WhatsApp: +86 17737712080



电子邮件:
E-mail: taka@uniaote.com



地址:
Address: 中国, 河南省, 郑州市高新技术开发区, 国家大学科技园 (东区), 10 栋
Building 10, National University S&T Park, Zhengzhou High-Tech Industrial
Development Zone, Henan Province, China.



电话:
Telephone: +86 13526775837



QQ: 601591828



Skype: yong2080



网址:
Website: www.uniaote.com



第一部分：公司简介

Chapter 1: Company Introduce

郑州永特机械有限公司成立于 2001 年，地处中国地理中心、铁路航空、高速公路枢纽城市郑州，是专业研制、开发、生产、销售各种类型的粉剂、颗粒剂、液体、膏体定量灌装生产线、自动称重配料生产线设备的企业。

Zhengzhou Uniaote Machinery Co., Ltd founded in 2001, is located in Zhengzhou, Henan province, the geographical center of China. The company is ideally situated with easy access to aviation, rail and truck transport services. We design and manufacture fully automated powder, granule and liquid product filling machines.

公司以客户为上帝，以质量求生存，以信誉求发展，秉承“没有最好、只有更好”的服务理念，坚持开拓创新，锲而不舍地追求更好地满足客户日益增长的多样化需求。客户的需求就是我们的追求，客户的满意就是我们坚持不懈的前进动力。

“There is no best, only better” are not just words to us but a way of life. We are able to better meet and exceed your diverse product needs by providing designs that are exactly suited to your requirements. Your satisfaction is our motivation.

我们将以蓬勃的朝气、饱满的热情、优质的服务欢迎各新老客户的到来，我们永远以为客户创造价值为己任，衷心期待成为您事业成功的合作伙伴，互惠互利，共创辉煌。

We encourage you to bring your filling needs to us and give us the opportunity to provide you with exactly what you need. We know that your products and business are valuable and when you choose one of our systems you are making a choice of guaranteed excellence.





公司主要产品有：

Our Main Products are the Following:

- 全自动包装生产线；
Fully Automatic Packing Line;
- 全自动颗粒产品灌装生产线；
Fully Automatic Granule Filling Lines;
- 全自动粉末产品灌装生产线；
Fully Automatic Powder Filling Lines;
- 全自动液体产品灌装生产线；
Fully Automatic Liquid Filling Lines;
- 全自动酱体产品灌装生产线；
Fully Automatic Sauce Filling Lines;
- 全自动称重配料 搅拌 包装生产线；
Fully Automatic Weighing, Ingredients, Mixing, Packaging Line;
- 1-5000 克粉末包装机；
1-5000g Semi Automatic Auger Powder Filling Machines;
- 30-2000 克颗粒称量机；
30-2000g Semi Automatic Granules Weighing Packing Machines (With Linear Weigher);
- 2-15 公斤粉末包装机；
2-15Kg Powder Packing Machines;
- 2-15 公斤颗粒包装机；
2-15Kg Granule Packing Machines;
- 10-50 公斤称重包装、灌装机组；
10 -50Kg Weighing and Packing / Filling Machine Unit;
- 500-1000 公斤吨袋包装机组；
500-1000Kg Ton Bag Packing Unit;
- 10-1000ml 液体定量灌装机；
10-1000ml Liquid Quantitative Filling Machine;
- 500-5000ml 液体定量灌装机；
500-5000ml Liquid Quantitative Filling Machine;



第二部分：技术参数
Chapter 2: Parameters

2.1 Auger Powder Filling Machine

粉剂自动定量包装机采用螺杆充填及电子称重反馈相结合的计量方式，微机控制，具有自动定量、自动充填、自动修正误差、计数、清料等功能。

Auger Powder Filling Machine adopts screw electronic weighing measurement mode feedback combining computer control, with automatic quantitative, automatic filling, automatic error correction, count, clear material and other functions.

<p>特点 Features</p>	<ul style="list-style-type: none"> ●适用于各种瓶、罐、袋的定量灌装，包装容器不受限制。 Suitable for all kinds of bottles, cans, bags of quantitative filling packaging container is not restricted. ●反馈数值可调，满足多种精度需要。 Feedback value can be adjustable, to meet a variety of precision required. ●充填电机转速可调，满足各种物料的要求。 The filling motor speed can be adjustable, to meet the requirements of various materials. ●全不锈钢材质，配上料机可实现自动料位控制。 All stainless steel, match with feeder enables automatic materials level control. 	
<p>Functions</p>	<ul style="list-style-type: none"> ●误差自动修正 Automatic error correction ●重量超差报警 Weight out-of-tolerance alarm ●产品计数 The product count 	
<p>Technical Parameters</p>	<ul style="list-style-type: none"> ●Fill Range: 1 gram to 5000 grams <i>Need to replace the Auger Filler and Tube to guaranteed accuracy and speed; details reference the "The Diameter List of Auger Filler Tube (Page 21)" please!</i> ●Fill Speed: 1200-3500 fills / hours ●Fill Control: Timer based / Sensor based ●Container: Bottle, jar, pouch, can ●Accuracy: 1.0 ●Hopper Volume: 50 liters ●Machine Dimensions: 690× 600×1900mm ●Power: 3P AC380 50Hz 0.9Kw 	











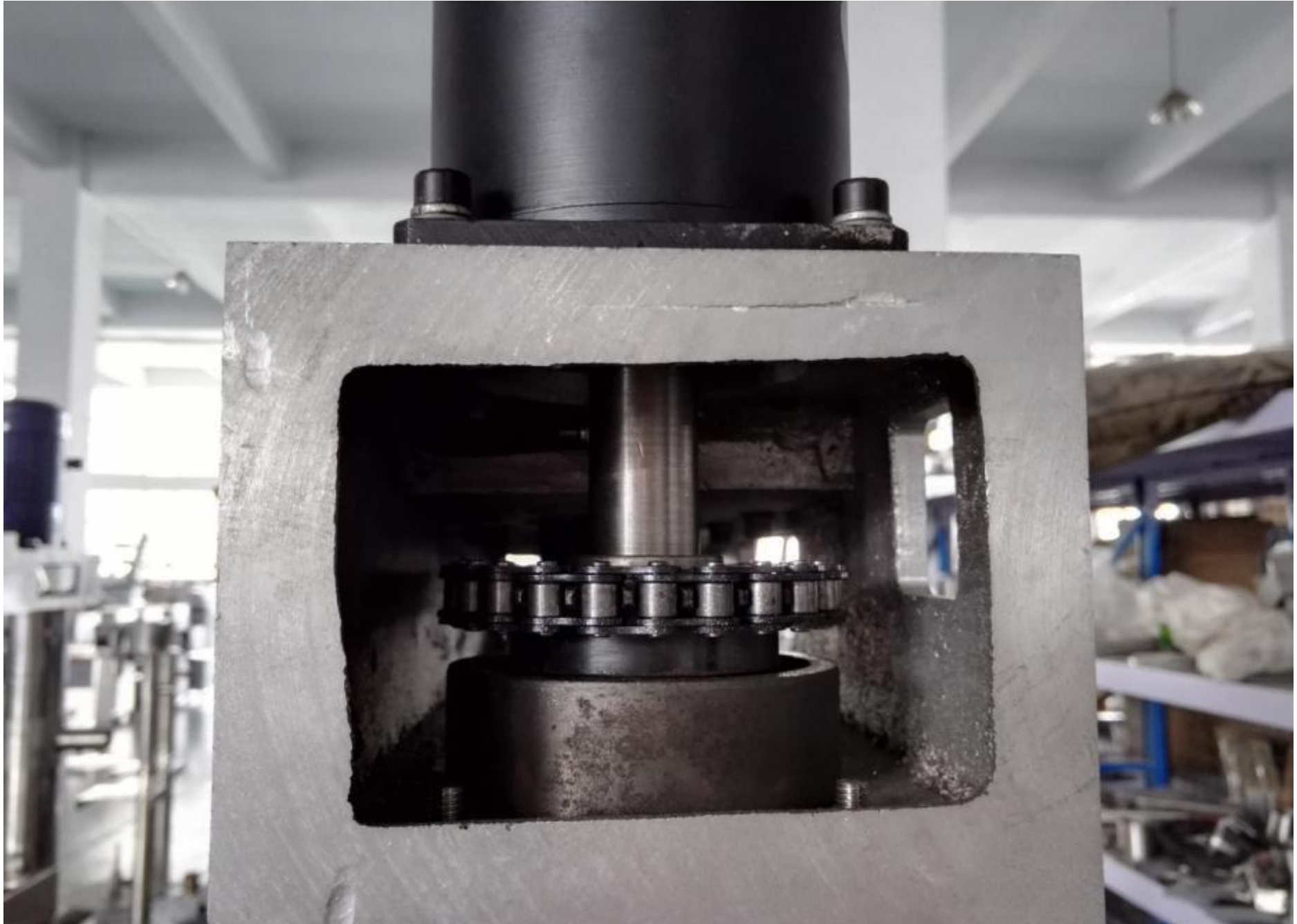









2.2 Powder Feeding Machine (Screw Conveyor)

振动式螺旋上料机适用于粉剂、粉粒混合型物料的自动上料。

Vibrating Screw Feeder is suitable for feeding powder, power and grain mixed material.

特点:

Features:

- 配合包装机使用，受包装机控制
Match up to the packing machines and filling machines, controlled by the packing machine or filling machine.
- 设置有退料开关，方便清料
Set the switch is provided with a return material, easy to clean material
- 料仓设置有振动器，上料更通畅
Hopper provided with vibrators, feeding unhindered.

技术参数:

Technical Parameters:

- 输送速度：0.5-3t/h
Conveying Speed: 0.5-3t/h
- 提升高度：1.7米(特殊高度可订做)
Lifting Height: 1.7m (Special requirements can be customized)
- 外形尺寸：长×宽×高(2300×800×2100)mm
Dimension: 2300×800×2100 mm
- 料仓容量：100-300 Kg
Hopper Capacity: 100-300 Kg
- 电源·功率：AC 220/380V 50/60Hz 0.75Kw
Power: AC 220/380V 50/60Hz 0.75Kw



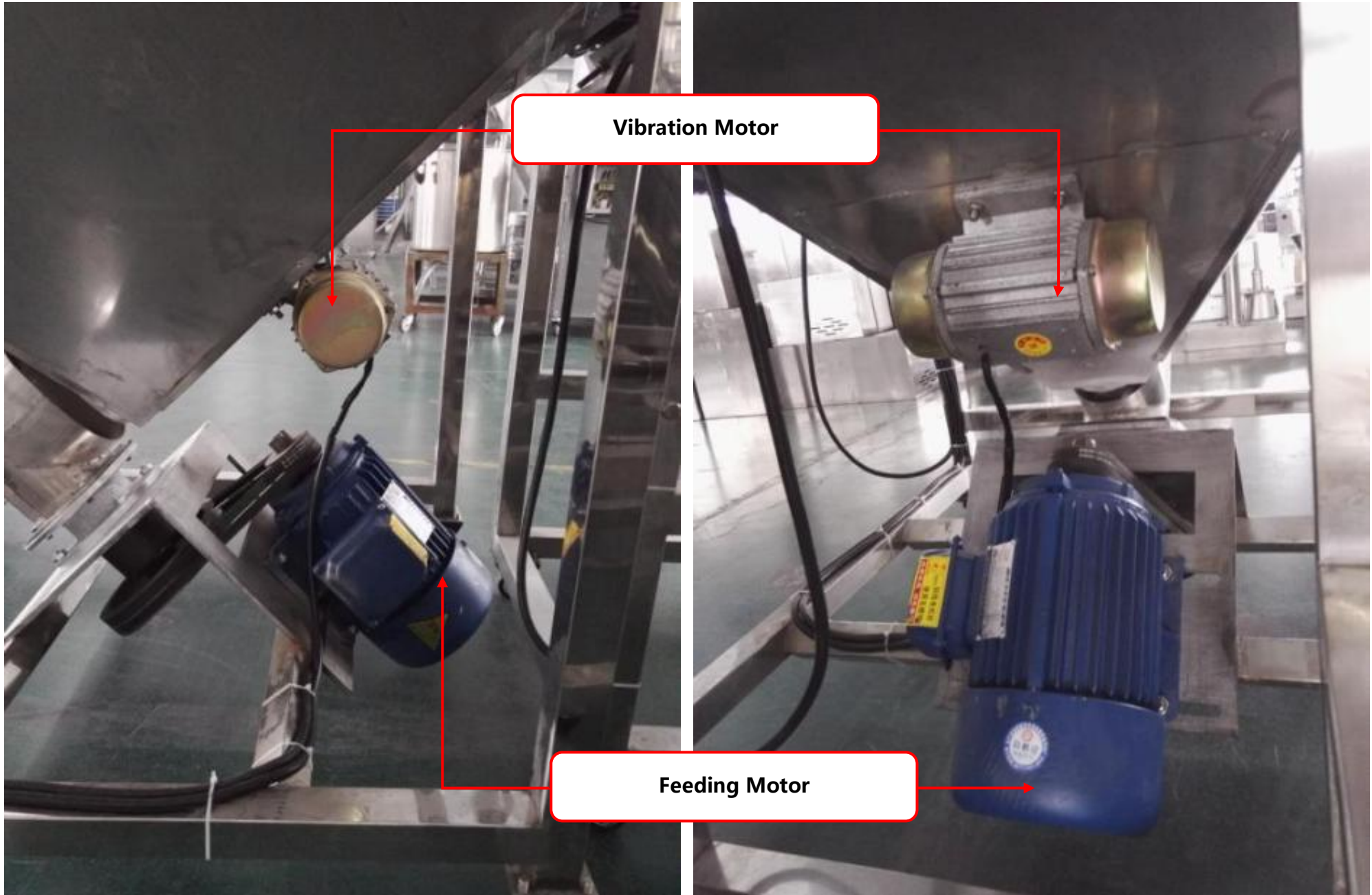

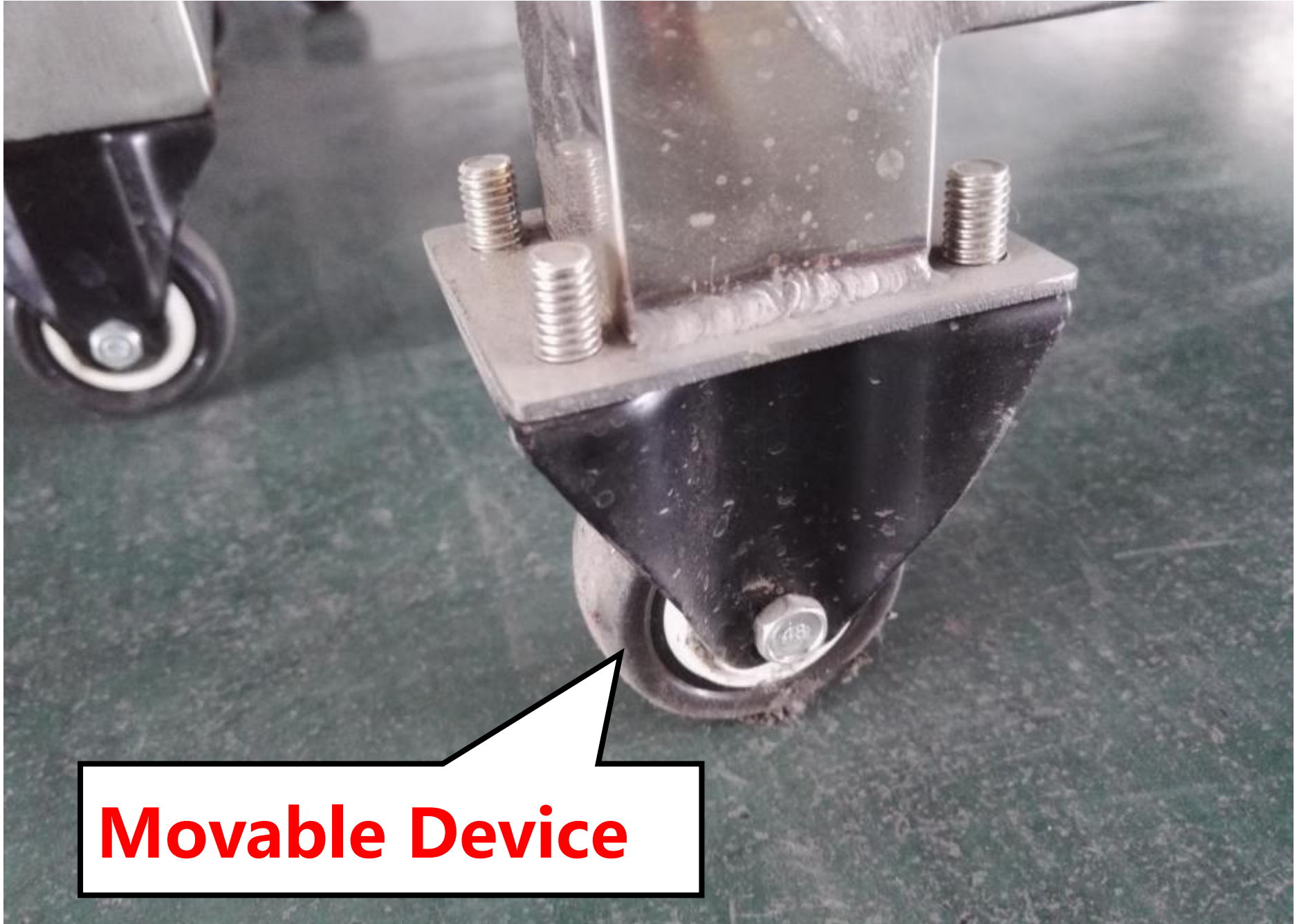





SUS304 Stainless Steel



Thickness of SUS304



3.3 Working Video:

The working video please visit: https://www.youtube.com/watch?v=H5V_4mUCkEU



The working video please visit: https://www.youtube.com/watch?v=H5V_4mUCkEU

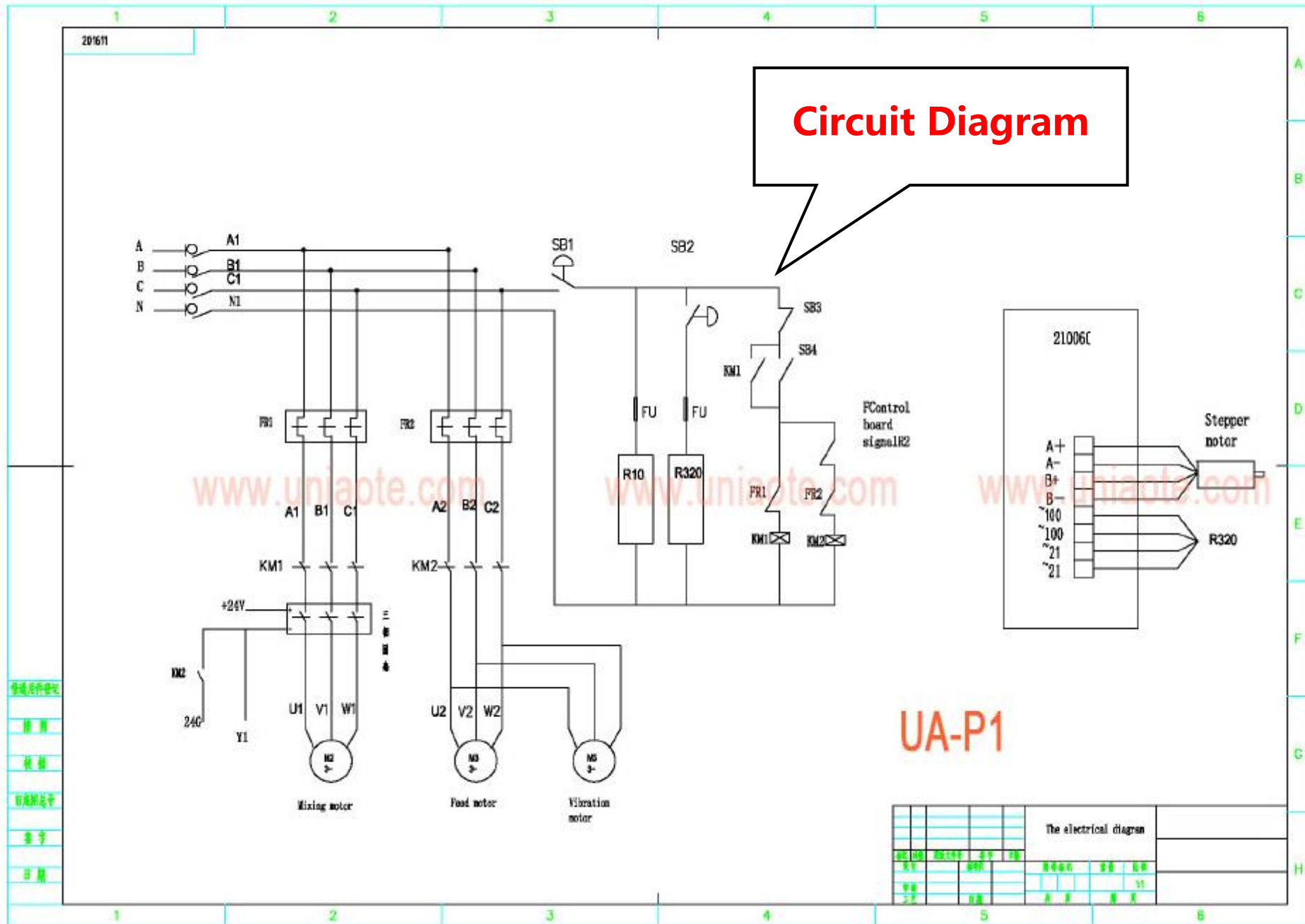



Packaging in Plywood Boxes

Auger Powder Filling Machine



Hopper of Screw Conveyor



Conveyor Tube of Screw Conveyor



Chapter 3: Quotation

Item	Name	Model	Quantity	FOB Price(USD)	Description
1	Semi Automatic Auger Powder Filling Machine	UA-P1	1 Set		1). Contains one set of auger screw 2). Filling Range: 1-5000g (need to replace auger filler tube)
2	Powder Feeding machine (Screw Conveyor)	UA-F-S	1 Set		Optional Φ114mm, 1.7m

Fill Weight	Diameter of Auger Filler Tube
1g-5g	φ20mm – φ22mm
5g-10g	φ20mm – φ26mm
10g-50g	φ26mm – φ28mm
40g-100g	φ30mm – φ34mm
100g-300g	φ38mm – φ40mm
300g-500g	φ40mm – φ45mm
500g-1000g	φ50mm – φ55mm
1000g-5000g	φ60mm – φ65mm
Remark: For reference only, subject to the advice of the engineer.	





销售条款

Sales Clauses

1. 支付条款: 30%预付款, 70%余款全清出货。
Payment Terms: 30% T/T as advance payment, 70% to be paid by T/T before goods leave exporter's factory.
2. 交付时间: 收到预付款后的 7 到 10 个工作日。
Delivery Time: 7-10 working days after receiving the prepayment.
3. 包装方式: 木箱包装。
Manner of Packing: Packed in wooden cases.
4. 保修时间: 12 个月。交付生产开始计算。
Warranty Time: 12 months. Beginning with the date our machinery has fully installed in clients plant.
5. 安装与调试:
Installation and Commissioning:
A:如果买方要求, 卖方应派一名或 2 名技术员直接安装、调试、试运行, 以及培训当地工人。
B:买方负责食宿, 回程机票, 技术人员的安全。此外, 买方负责技术员的工资, 每人每天 120 美元。
C:买方可根据卖方提供的视频资料自行安装设备。
A: If the buyer requires, the seller shall send one or two technician to direct installation, commissioning, trial-run, and training local workers.
B: The buyer is responsible for board and lodging; return tickets, safety of technician. In addition, the buyer is responsible for technician's salary, USD120 per day per person.
C: The buyer also can according to the video provided by the seller to install the equipment by themselves.
6. 报价有效期: 有效期 10 天。
Validity Date: The quotation is valid for 10 day.



第四部分：车间展示
Chapter 4: Workshop show

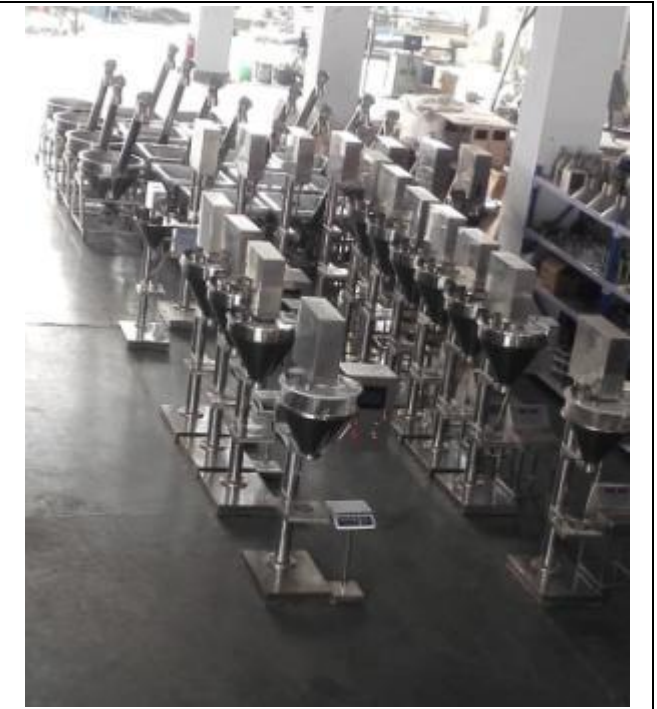



第五部分：客户案例
Chapter 5: Customer Case

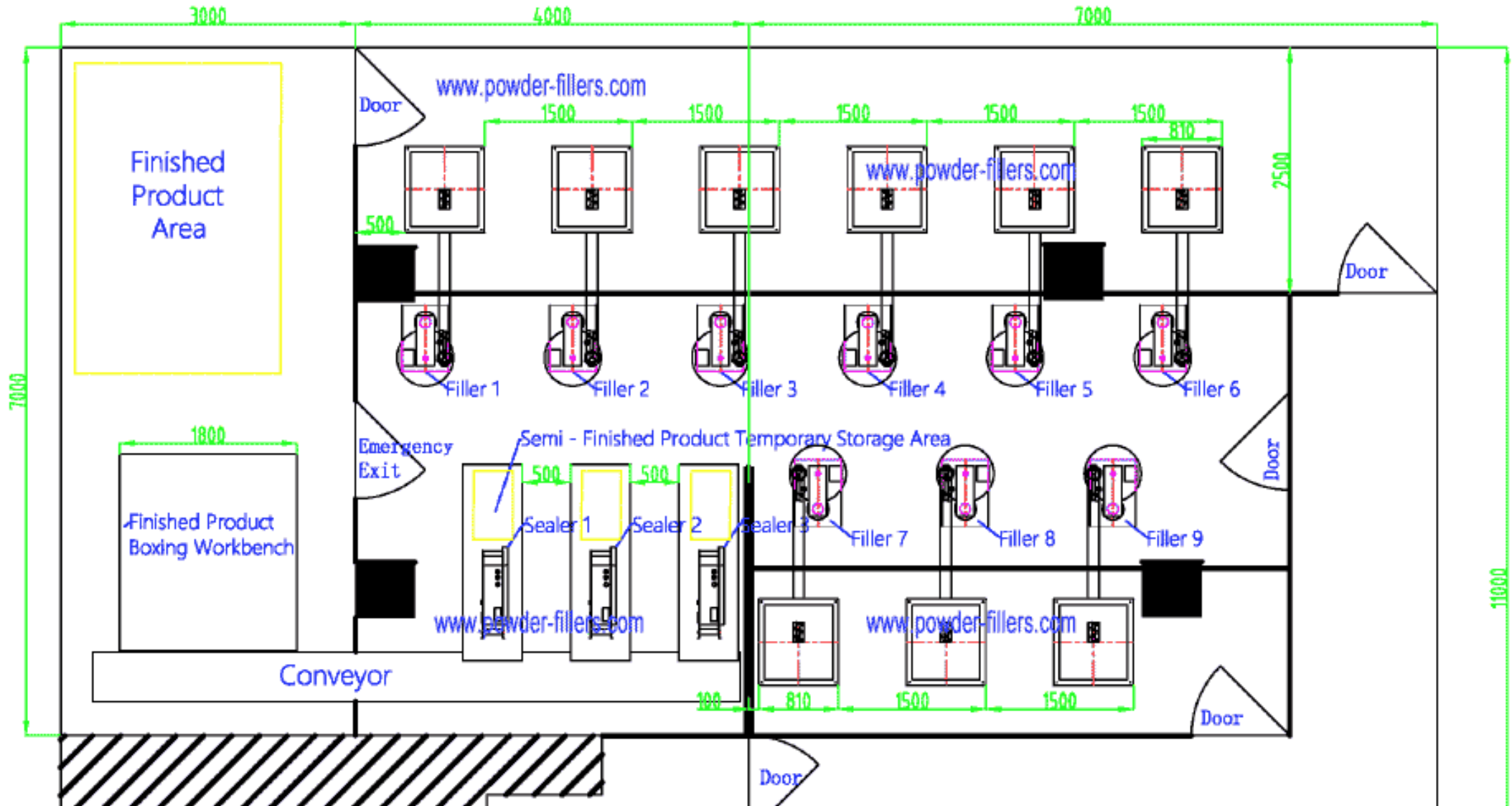





第六部分：客户交流

Chapter 6: Technical communication



The Customers of Arab



The Customer of Australian



The Customer of Nigeria



The Customers of Lebanon



Exhibition



Exhibition



第七部分：出口货物运输
Chapter 7: The Transport of Export Cargo

